

Crystal HC49/S -- HC49/SS

- Applications
Video camera ▪ Audio Equipment ▪ Cordless Telephones ▪ HDD
- Features
Dimensions(11.05×4.65×H)
Industry Standard Package
Leadless Type ▪ Resistance Sealed
Tight Tolerance and Stability
RoHS Compliant

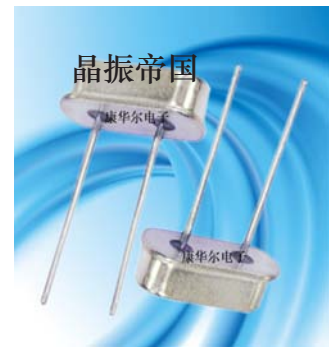

▼ Specifications

Type	HC49/S -- HC/49SS	
Nominal frequency range	3.500~40.000MHz	30.000~80.000MHz
Crystal cut	Fundamental [AT-cut]	3rd overtone[AT-cut]
Storage temperature range	-40~+90°C	
Operating temperature range	-10~+70°C(-40~+85°C)	
Frequency temperature characteristics (Ref. to +25°C)	± 30	
Frequency tolerance(at +25°C)	±30 -- ± 50	
Equivalent series resistance	Please refer to the following ESR Table	
Load capacitance	series,10pF,12pF,16pF	
Shunt capacitance	5pF max.	
Level of drive	10μW(100μW max.)	

Package quantity : 1,000pcs max./box.

▼ Outline Dimensions [unit:mm]

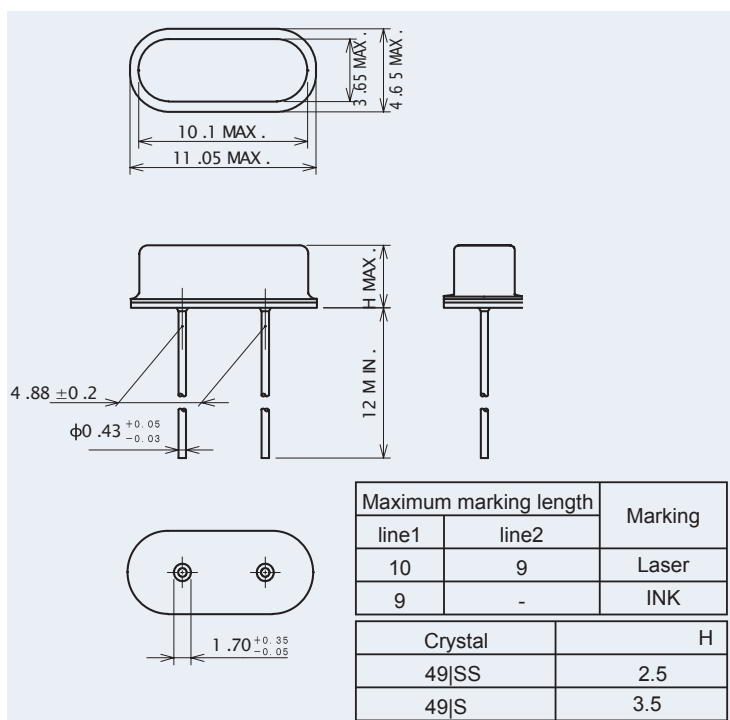

▼ ESR Table

Frequency[MHz]	
Fundamental	ESR[Ω]
3.500~3.999	150
4.000~4.999	120
5.000~5.999	100
6.000~8.999	80
9.000~9.999	60
10.000~12.999	50
13.000~18.999	40
19.000~40.000	30
3rd overtone	ESR[Ω]
30.000~44.999	80
45.000~59.999	70
60.000~80.000	60